

ITEM NO.	QTY.	Tegningsnummer	Beskrivelse	Material	Vekt	Dim
1	2	103773-03	Rør Ø76,1x2,9	S355	3.72	3mm
2	2	103773-01		S355	5.61	4 mm
3	7	103773-Spiler		Cedar	4.42	78x48
4	2	103773-05		S355	0.05	2 mm

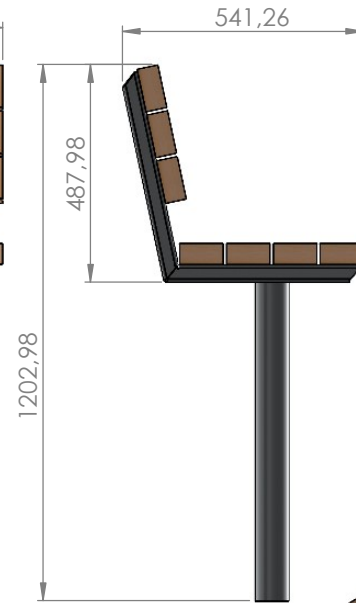

VMV produserer kun stålet
Kunden ordner galvanisering/lakking og tre.

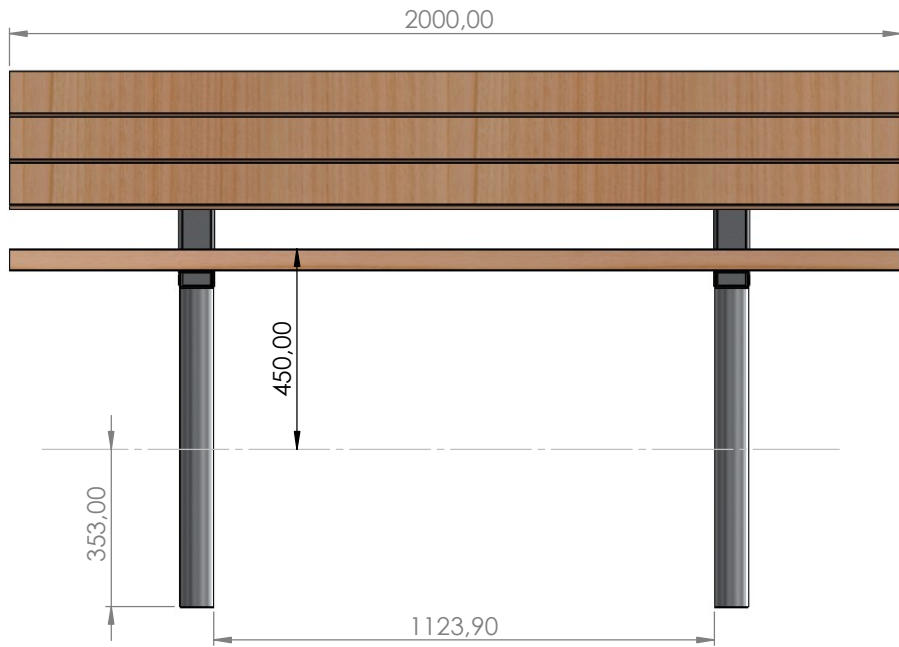

REVISJON					
SONE	REV.	BESKRIVELSE	DATO	ENDRET AV	GODKJENT AV
Tegnet av: LHM		Dato: 2021-10-04			
		Tegningsnummer:	Revisjon:	Side:	Denne tegningen er vår eiendom, kopiering, bruk eller videreformidling av denne tegningen uten vår tilatelse er ikke tillat. © VMV Production AS
		103773	03	1 AV 5	
Konstruert av: LHM		Dato: 2021-10-04			
		Kundens tegn. nr.: Detaljplan Multibenk A-001			
Tittel: Multibenk				Målestokk A3: 1:20	Generelle toleranser NS-ISO 2768-1:



ITEM NO.	QTY.	Tegningsnummer	Beskrivelse	Material	Vekt	Dim
1	1	103773-03	Rør Ø76,1x2,9	S355	3.72	3mm
2	1	103773-01		S355	5.61	4 mm
3	1	103773-05		S355	0.05	2 mm

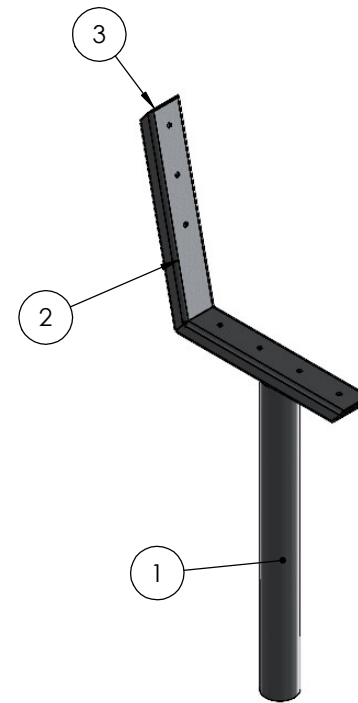
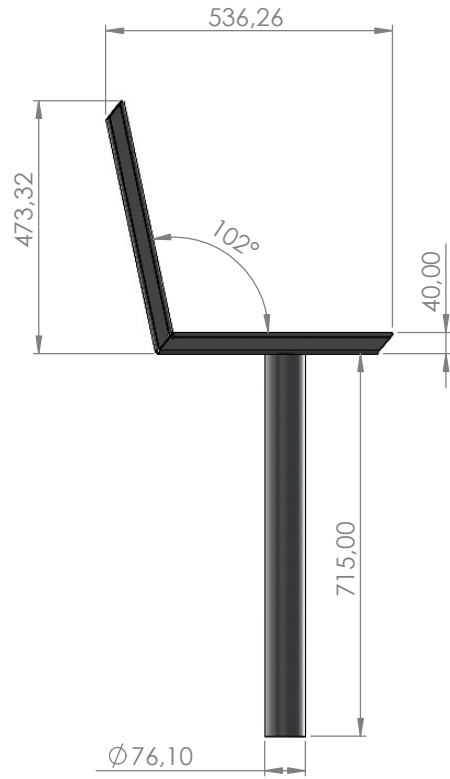

2 stk til hver benk

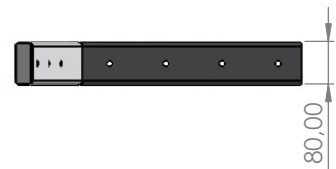



Tegnet av: LHM	Dato: 2021-10-04	Tegningsnummer: 103773	Revisjon: 03	Side: 2 AV 5	Denne tegningen er vår eiendom, kopiering, bruk eller videreformidling av denne tegningen uten vår tillatelse er ikke tillat. © VMV Production AS
Konstruert av: LHM	Dato: 2021-10-04	Kundens tegn. nr.: Detaljplan Multibenk A-001			
Tittel: Multibenk		Målestokk A3: 1:20		Generelle toleranser NS-ISO 2768-1:	

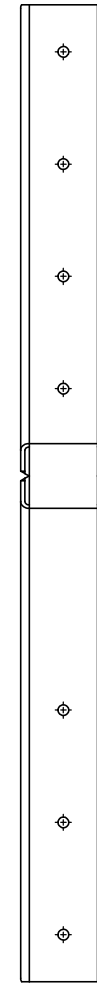
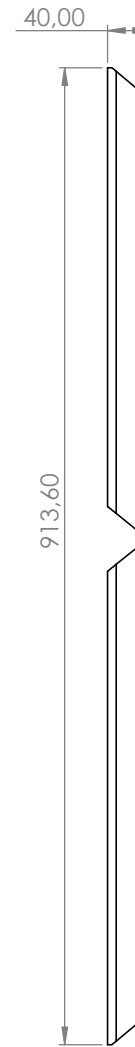
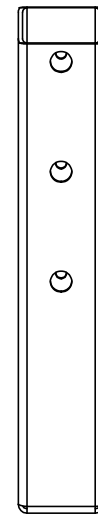
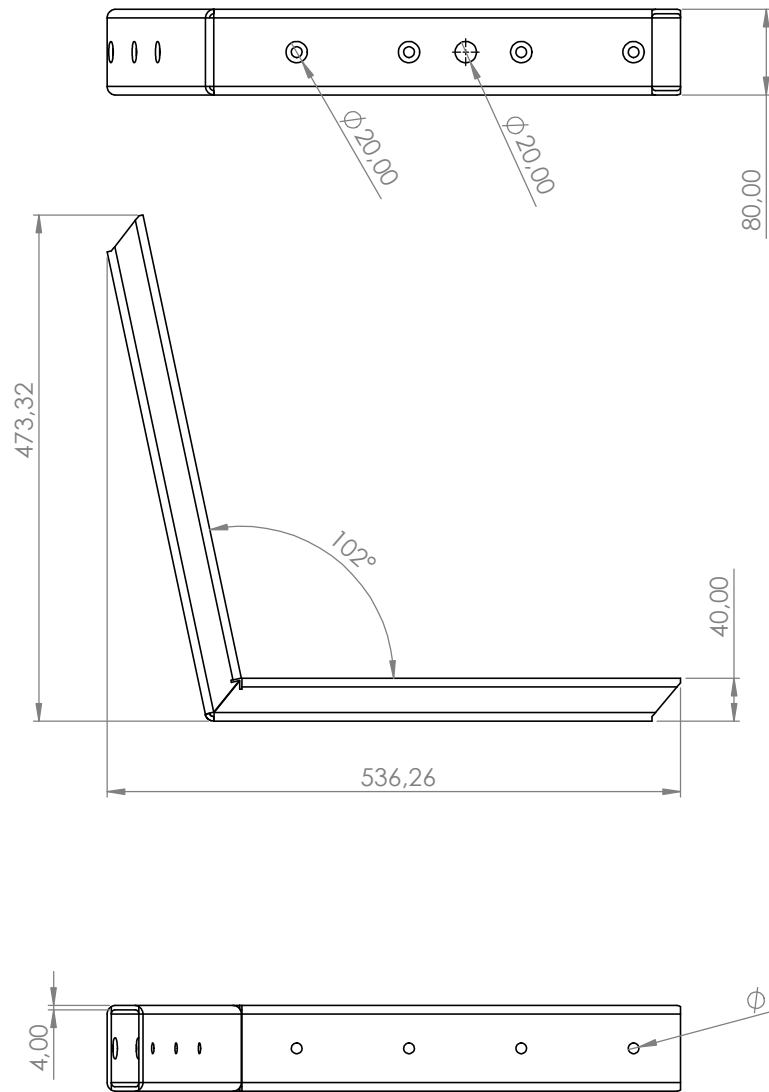

ITEM NO.	QTY.	Tegningsnummer	Beskrivelse	Material	Vekt	Dim
1	1	103773-01		S355	5.61	4 mm

Profil for skjæring, knekkes opp ved sveising.



Tegnet av: LHM	Dato: 2021-10-04	Tegningsnummer: 103773	Revisjon: 03	Side: 3 AV 5	Denne tegningen er vår eiendom, kopiering, bruk eller videreføring av denne tegningen uten vår tillatelse er ikke tillat. © VMV Production AS
Konstruert av: LHM	Dato: 2021-10-04	Kundens tegn. nr.: Detaljplan Multibenk A-001		Målestokk A3: 1:5	
Tittel: Multibenk					Generelle toleranser NS-ISO 2768-1:



ITEM NO.	QTY.	Tegningsnummer	Beskrivelse	Material	Vekt	Dim
1	1	103773-03	Rør Ø76,1x2,9	S355	3.72	3mm

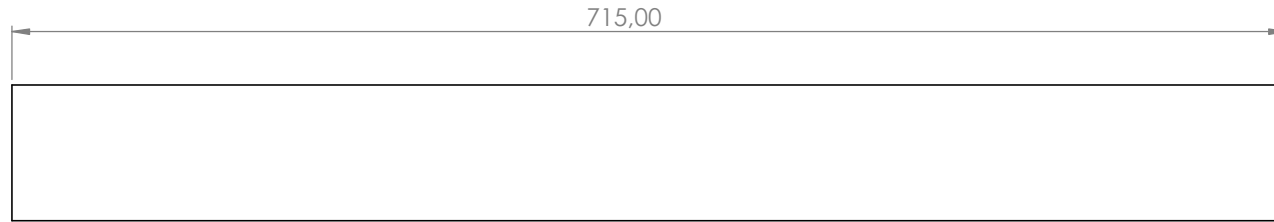
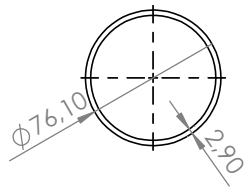

Tegnet av: LHM	Dato: 2021-10-04	Tegningsnummer: 103773	Revisjon: 03	Side: 4 AV 5	Denne tegningen er vår eiendom, kopiering, bruk eller videreføring av denne tegningen uten vår tillatelse er ikke tillat. © VMV Production AS
Konstruert av: LHM	Dato: 2021-10-04	Kundens tegn. nr.: Detaljplan Multibenk A-001			
Tittel: Multibenk			Målestokk A3: 1:5		Generelle toleranser NS-ISO 2768-1:

ITEM NO.	QTY.	Tegningsnummer	Beskrivelse	Material	Vekt	Dim
1	1	103773-05		S355	0.05	2 mm

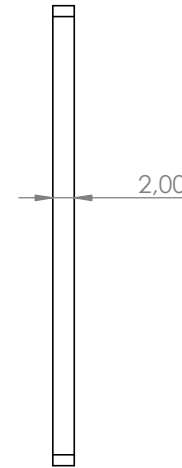
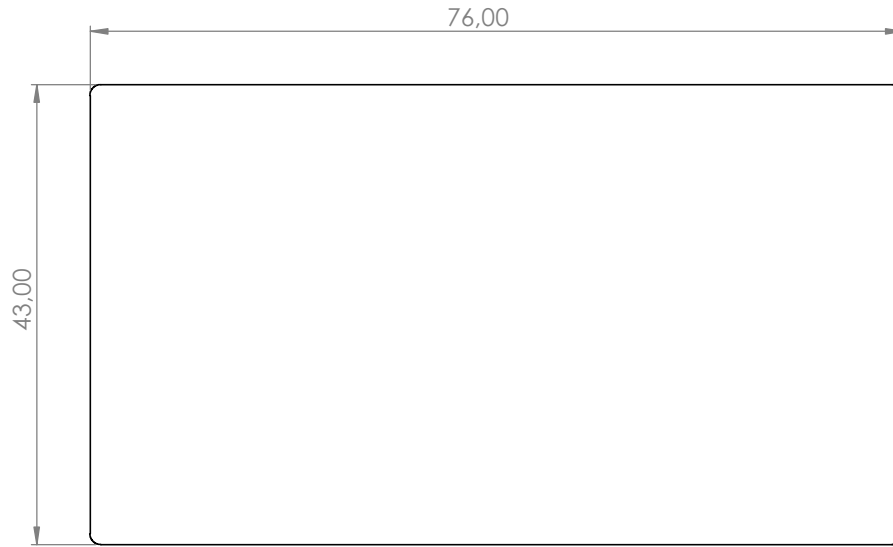

Tegnet av: LHM	Dato: 2021-10-04	Tegningsnummer: 103773	Revisjon: 03	Side: 5 AV 5	Denne tegningen er vår eiendom, kopiering, bruk eller videreformidling av denne tegningen uten vår tillatelse er ikke tillat. © VMV Production AS
Konstruert av: LHM	Dato: 2021-10-04	Kundens tegn. nr.: Detaljplan Multibenk A-001		Målestokk A3: 2:1	
Tittel: Multibenk					Generelle toleranser NS-ISO 2768-1:
					