

ITEM NO.	QTY.	Tegningsnummer	Beskrivelse	Material	Vekt	Dim
1	2	103769-01	Firkant 100x60x6	S355	20.22	6 mm
2	1	103769-02	Vinkel 100x65x7	S355	3.12	7 mm
3	1	103769-03	Vinkel 100x65x7	S355	2.27	7 mm
4	7	103769-Spiller 98x48		Cedar	4.07	98x48
5	1	103769-02-MIR		S355	3.12	7 mm
6	1	103769-03-MIR		S355	2.27	7 mm

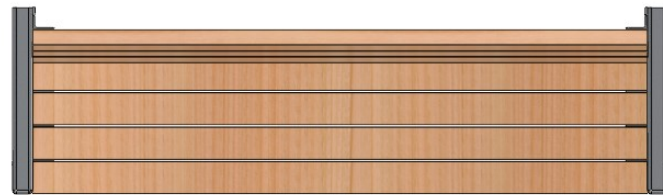

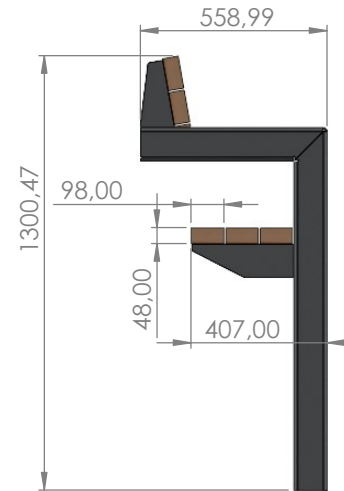

REVISJON					
SONE	REV.	BESKRIVELSE	DATO	ENDRET AV	GODKJENT AV
Tegnet av: LHM	Dato: 2021-10-05	Tegningsnummer: 103769	Revisjon: 04	Side: 1 AV 5	Denne tegningen er vår eiendom, kopiering, bruk eller videreformidling av denne tegningen uten vår tilatelse er ikke tillat. © VMV Production AS
Konstruert av: LHM	Dato: 2021-10-04	Kundens tegn. nr.: Halv Vera	Rev.: A-001		
Tittel: Halv Vera				Målestokk A3: 1:20	Generelle toleranser NS-ISO 2768-1: C

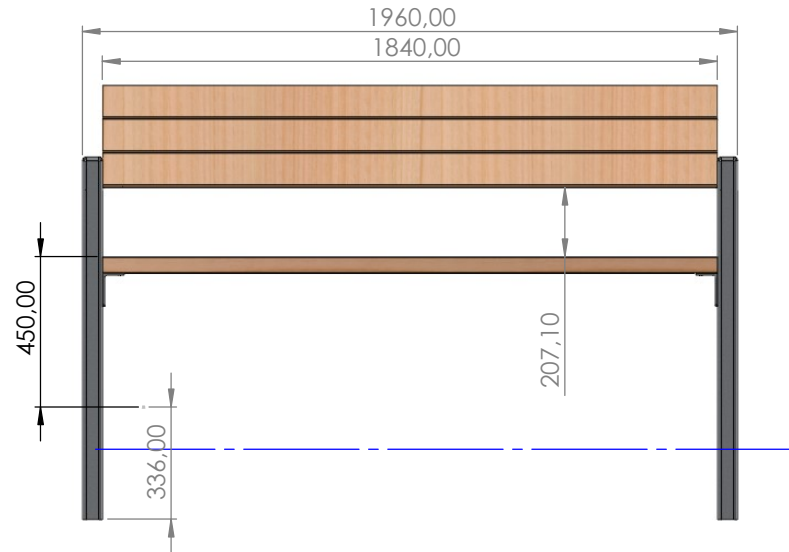

ITEM NO.	QTY.	Tegningsnummer	Beskrivelse	Material	Vekt	Dim
1	1	103769-01	Firkant 100x60x6	S355	20.22	6 mm
2	1	103769-02	Vinkel 100x65x7	S355	3.12	7 mm
3	1	103769-03	Vinkel 100x65x7	S355	2.27	7 mm

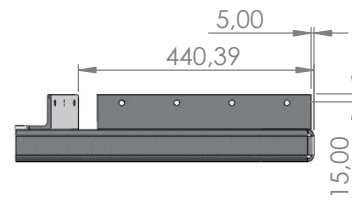
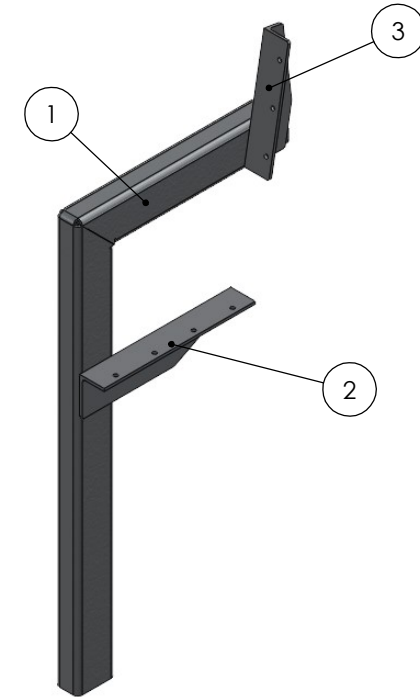
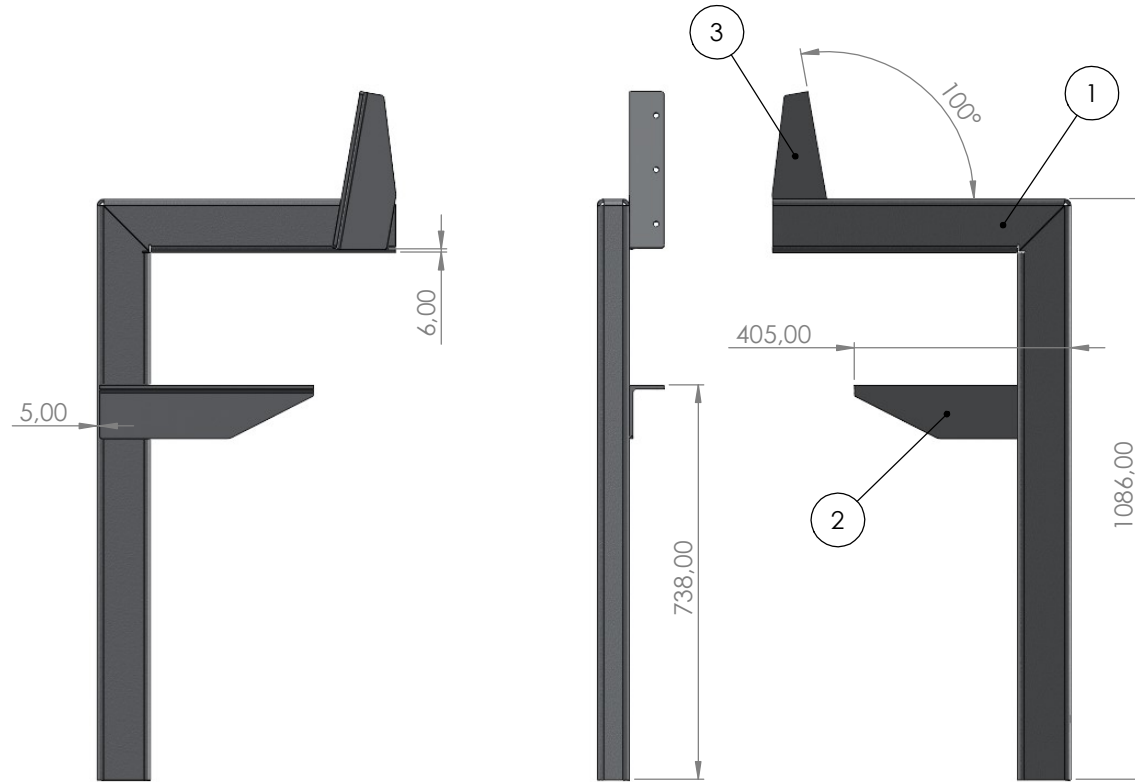
Produseres høyre/venstre



Tegnet av: LHM	Dato: 2021-10-05	Tegningsnummer: 103769	Revisjon: 04	Side: 2 AV 5	Denne tegningen er vår eiendom, kopiering, bruk eller videreformidling av denne tegningen uten vår tillatelse er ikke tillat. © VMV Production AS
Konstruert av: LHM	Dato: 2021-10-04	Kundens tegn. nr.: Halv Vera	Rev.: A-001	Målestokk A3: 1:20	
Tittel: Halv Vera				Generelle toleranser NS-ISO 2768-1: C	

**VMV**  
Production AS

1 2 3 4 5 6 7 8

ITEM NO.	QTY.	Tegningsnummer	Beskrivelse	Material	Vekt	Dim
1	1	103769-01	Firkant 100x60x6	S355	20.22	6 mm

F

E

D

C

B

A

F

E

D

C

B

A

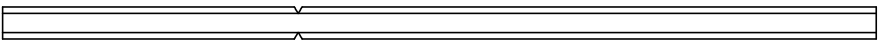
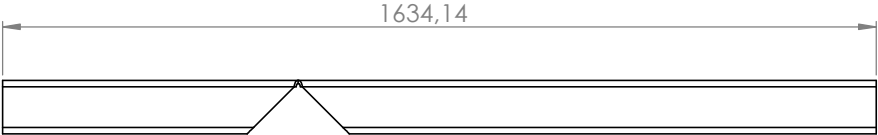
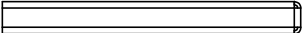
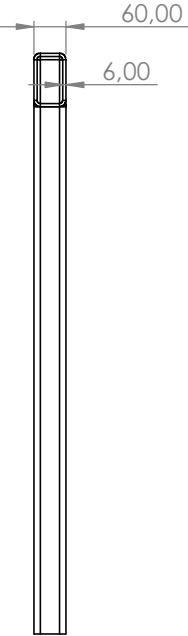
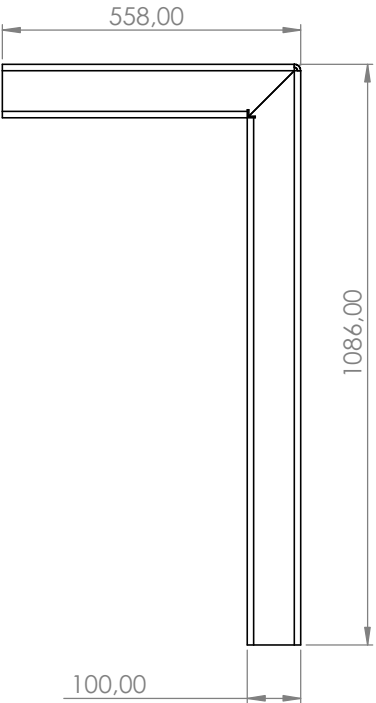

1 2 3 4 5 6 7 8

Tegnet av: LHM	Dato: 2021-10-05	Tegningsnummer: 103769	Revisjon: 04	Side: 3 AV 5	Denne tegningen er vår eiendom, kopiering, bruk eller videreformidling av denne tegningen uten vår tillatelse er ikke tillat. © VMV Production AS
Konstruert av: LHM	Dato: 2021-10-04	Kundens tegn. nr.: Halv Vera		Rev.: A-001	
Tittelt: Halv Vera			Målestokk A3: 1:10		Generelle toleranser NS-ISO 2768-1: C



1 2 3 4 5 6 7 8

ITEM NO.	QTY.	Tegningsnummer	Beskrivelse	Material	Vekt	Dim
1	1	103769-02	Vinkel 100x65x7	S355	3.12	7 mm

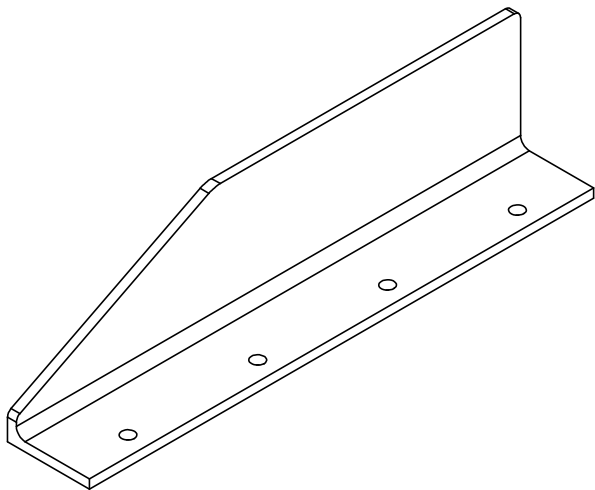
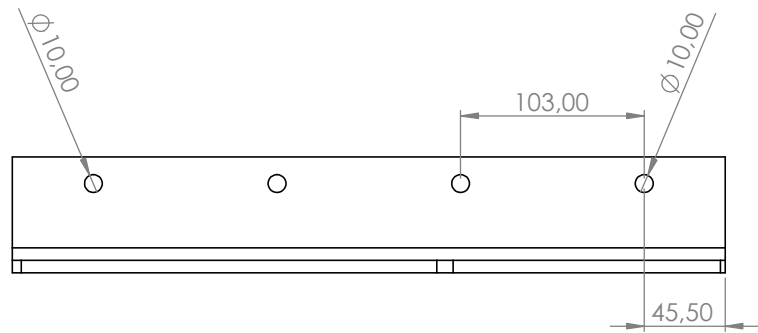
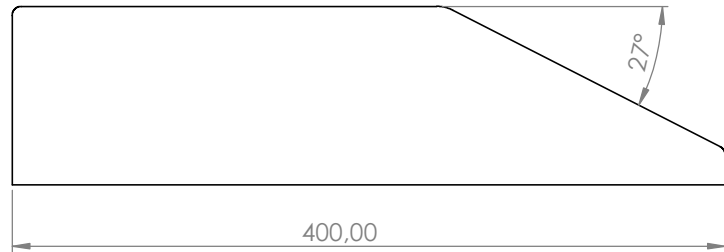
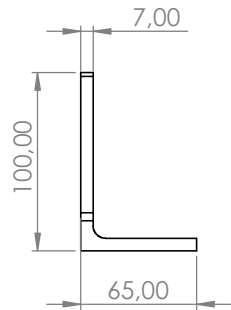

Tegnet av: LHM	Dato: 2021-10-05	Tegningsnummer: 103769	Revisjon: 04	Side: 4 AV 5	Denne tegningen er vår eiendom, kopiering, bruk eller videreformidling av denne tegningen uten vår tillatelse er ikke tillat. © VMV Production AS
Konstruert av: LHM	Dato: 2021-10-04	Kundens tegn. nr.: Halv Vera	Rev.: A-001	Målestokk A3: 1:5	
Tittel: Halv Vera					Generelle toleranser NS-ISO 2768-1: C
					

1 2 3 4 5 6 7 8

F  
E  
D  
C  
B  
A

F  
E  
D  
C  
B  
A

ITEM NO.	QTY.	Tegningsnummer	Beskrivelse	Material	Vekt	Dim
1	1	103769-03	Vinkel 100x65x7	S355	2.27	7 mm

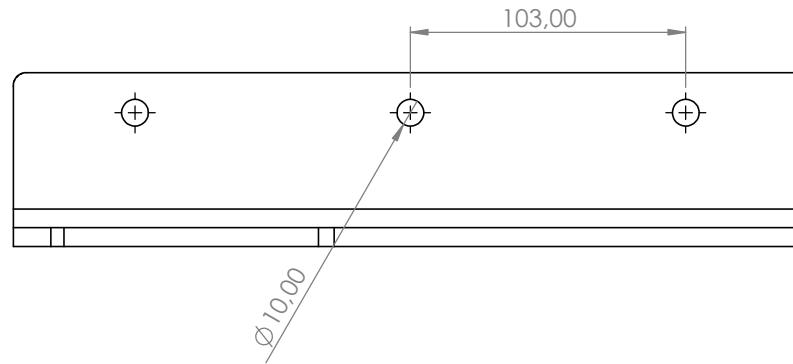
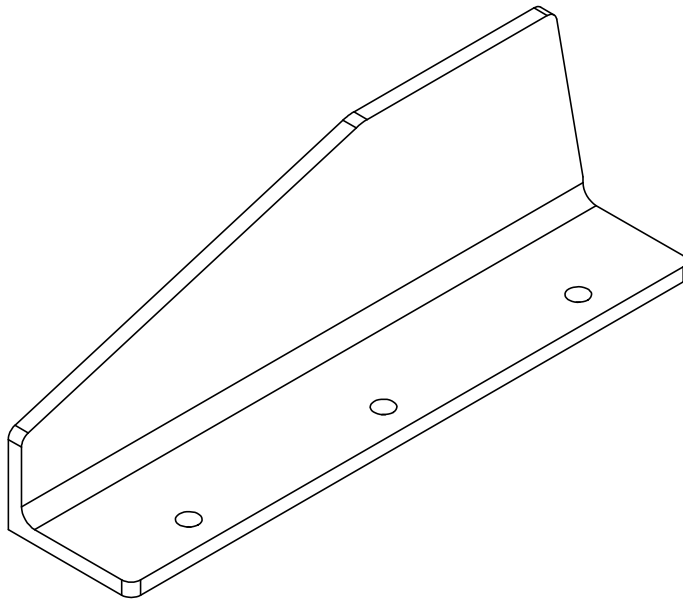
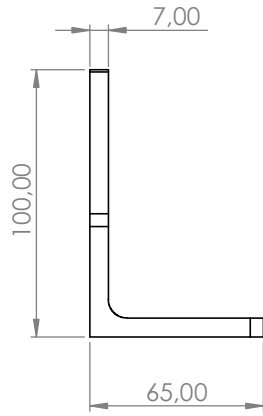

Tegnet av: LHM	Dato: 2021-10-05	Tegningsnummer: <b>103769</b>	Revisjon: <b>04</b>	Side: <b>5 AV 5</b>	Denne tegningen er vår eiendom, kopiering, bruk eller videreformidling av denne tegningen uten vår tillatelse er ikke tillat. © VMV Production AS
Konstruert av: LHM	Dato: 2021-10-04	Kundens tegn. nr.: Halv Vera	Rev.: A-001	Målestokk A3: <b>1:5</b>	
Tittel: <b>Halv Vera</b>				 Generelle toleranser NS-ISO 2768-1: C	

