

1 2 3 4 5 6 7 8

ITEM NO.	QTY.	Tegningsnummer	Beskrivelse	Material	Vekt	Dim
1	2	105844-01	Firkant 100x60x4	S355	15.47	4 mm
2	1	105844-02	Vinkel 100x65x7	S355	3.12	7 mm
3	1	105844-03	Vinkel 100x65x7	S355	1.62	7 mm
4	6	105844-Spiler 98x48		Cedar	4.07	98x48
5	1	105844-02-MIR		S355	3.12	7 mm
6	1	105844-03-MIR		S355	1.62	7 mm
7	4	105844-04		S355	0.11	3 mm

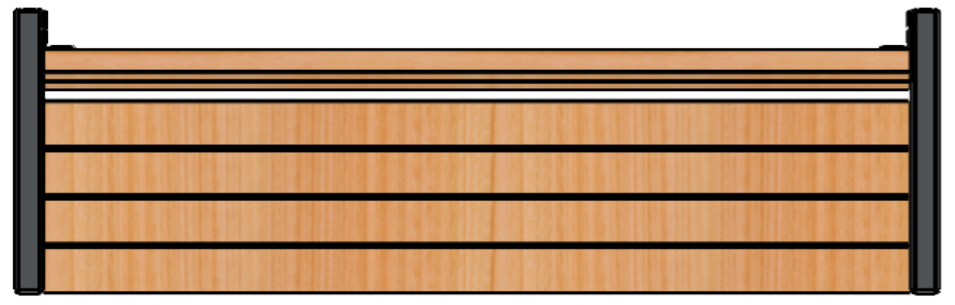
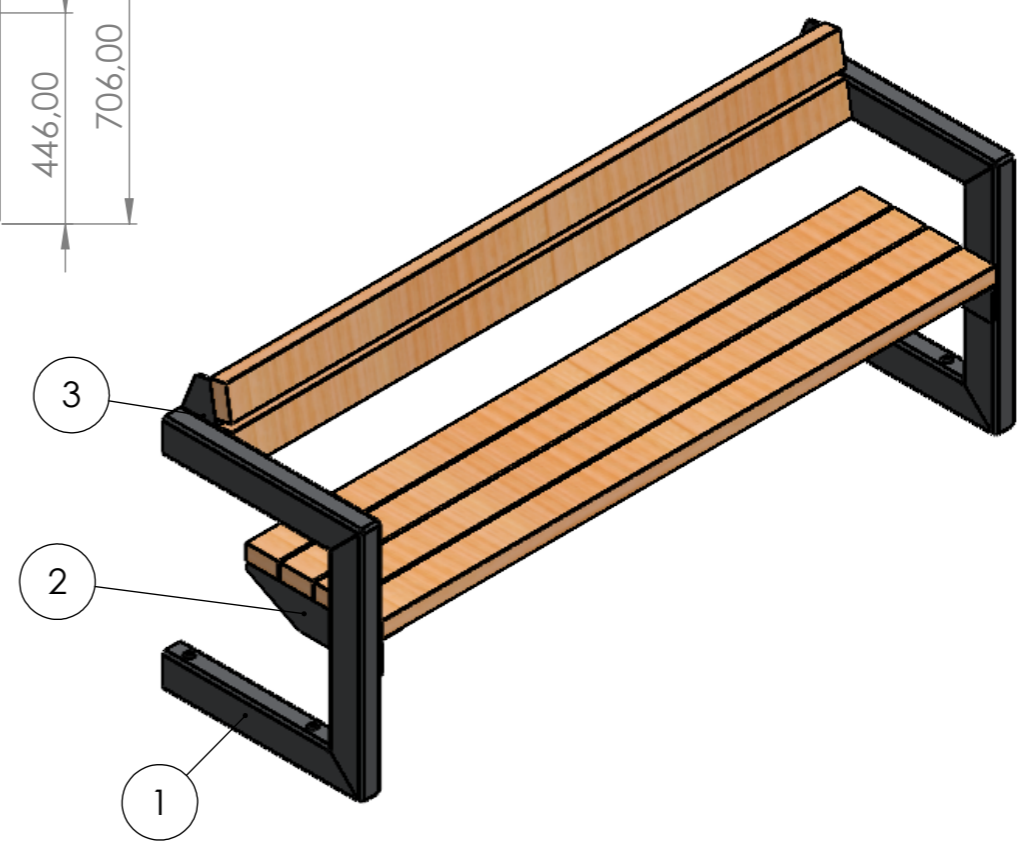
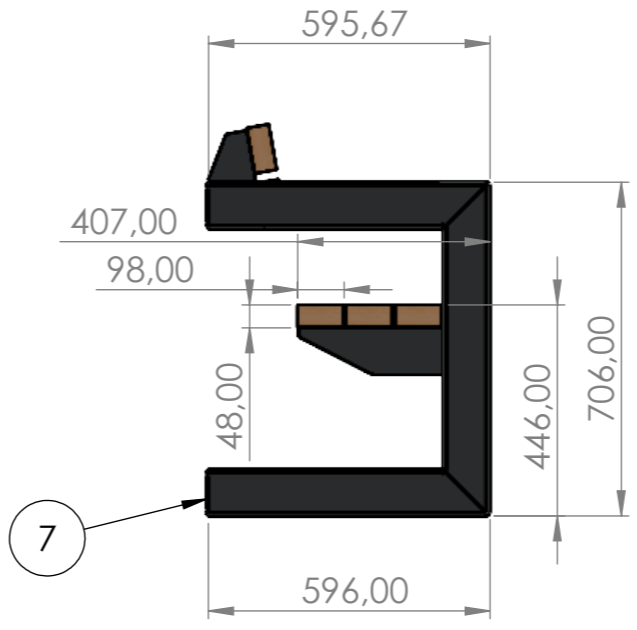
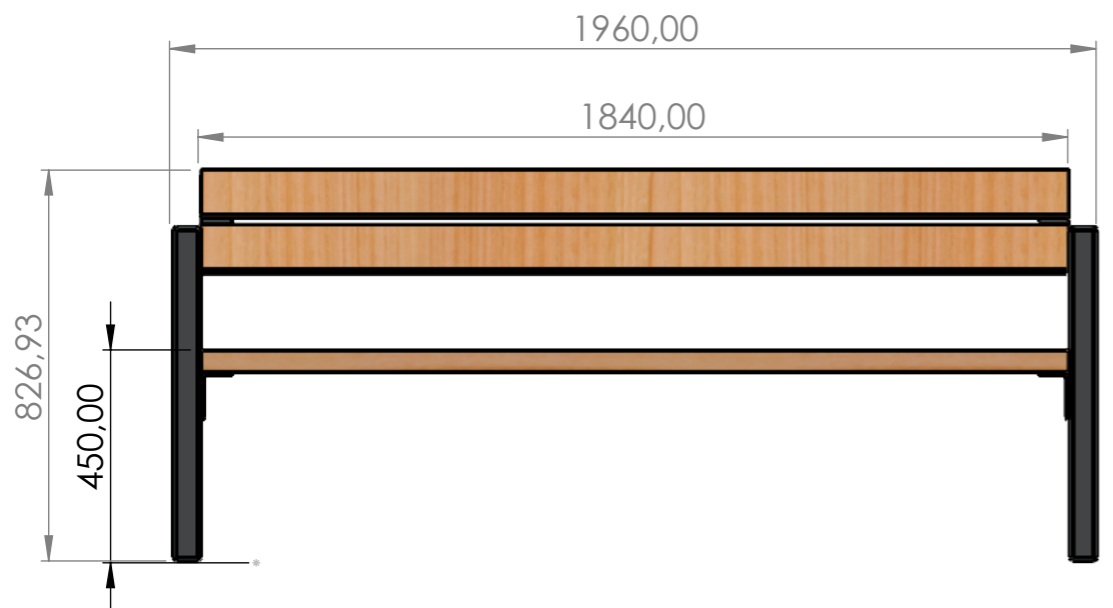

REVISJON					
SONE	REV.	BESKRIVELSE	DATO	ENDRET AV	GODKJENT AV
Tegnet av: LHM	Dato: 2022-10-14	<b>Tegningsnummer:</b> 105844	<b>Revisjon:</b> 01	Side: 1 AV 6	Denne Tegningen er vår eiendom, kopiering, bruk eller videreformidling av denne tegninger uten vår tillatelse er ikke tillat. © VMV Production AS
Konstruert av: LHM	Dato: 2021-10-04	Kundens tegn. nr.: Halv Vera	Rev.:		
Titel: Halv Vera			Målestokk A3: 1:20		Generelle toleranser NS-ISO 2768-1: C

1 2 3 4 5 6 7 8

ITEM NO.	QTY.	Tegningsnummer	Beskrivelse	Material	Vekt	Dim
1	1	105844-01	Firkant 100x60x4	S355	15.47	4 mm
2	1	105844-02	Vinkel 100x65x7	S355	3.12	7 mm
3	1	105844-03	Vinkel 100x65x7	S355	1.62	7 mm
4	2	105844-04		S355	0.11	3 mm

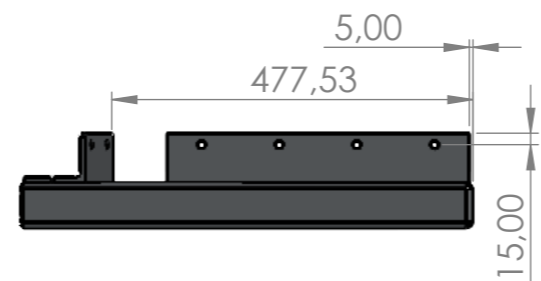
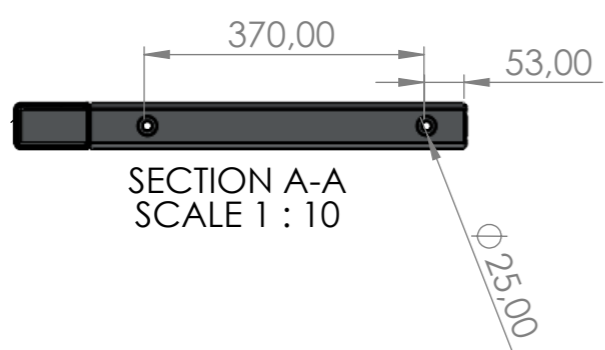
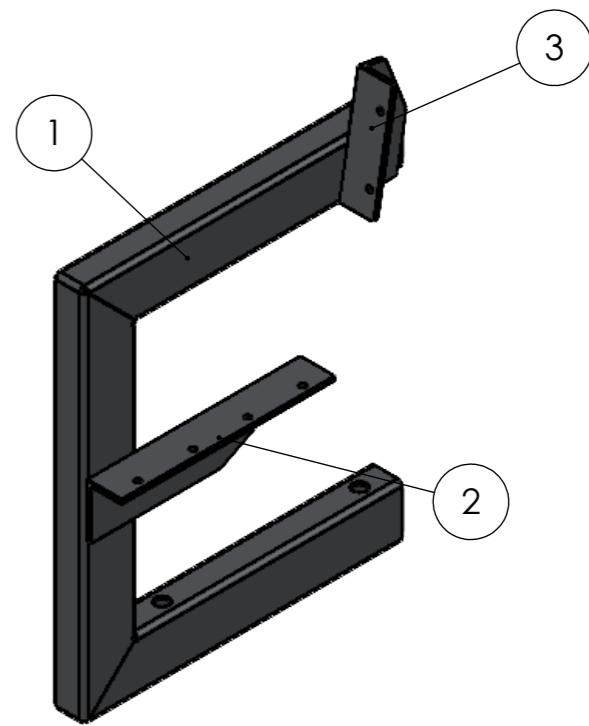
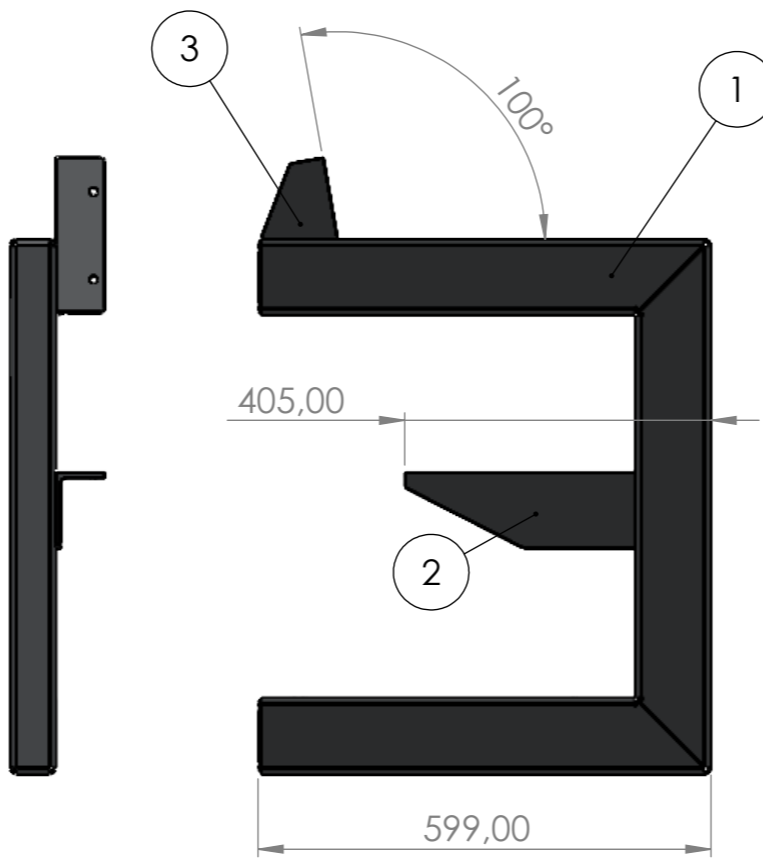
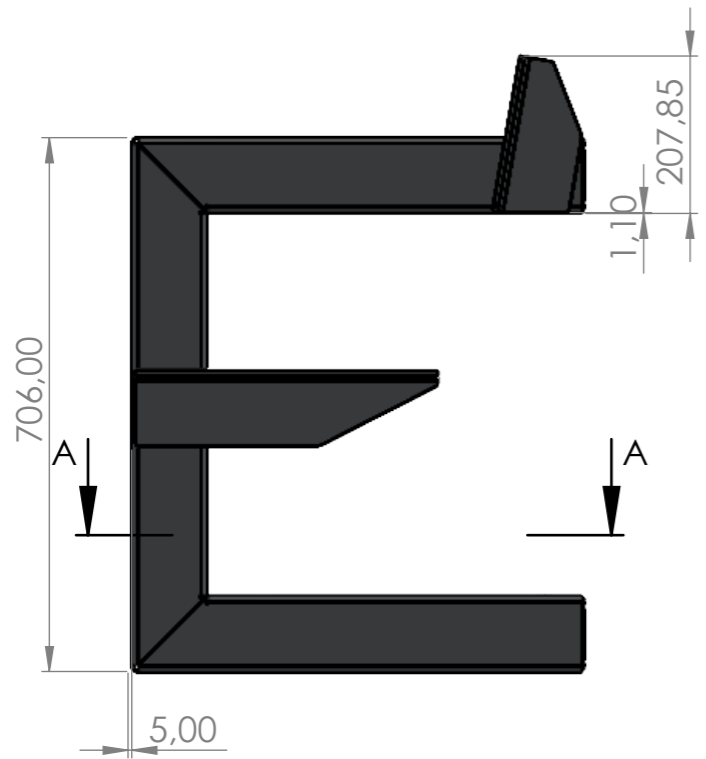
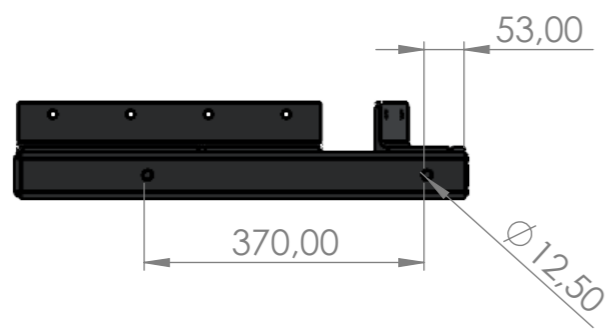

Produseres høyre/venstre

Tegnet av: LHM	Dato: 2022-10-14	<b>Tegningsnummer:</b> 105844	<b>Revisjon:</b> 01	Side: 2 AV 6	Denne Tegningen er vår eiendom, kopiering, bruk eller videreformidling av denne tegninger uten vår tillatelse er ikke tillat. © VMV Production AS
Konstruert av: LHM	Dato: 2021-10-04	Kundens tegn. nr.: Halv Vera		Rev.:	
Titel: Halv Vera		Målestokk A3: 1:20		Generelle toleranser NS-ISO 2768-1: C	



1 2 3 4 5 6 7 8

ITEM NO.	QTY.	Tegningsnummer	Beskrivelse	Material	Vekt	Dim
1	1	105844-01	Firkant 100x60x4	S355	15.47	4 mm

F  
E  
D  
C  
B  
A

F  
E  
D  
C  
B  
A

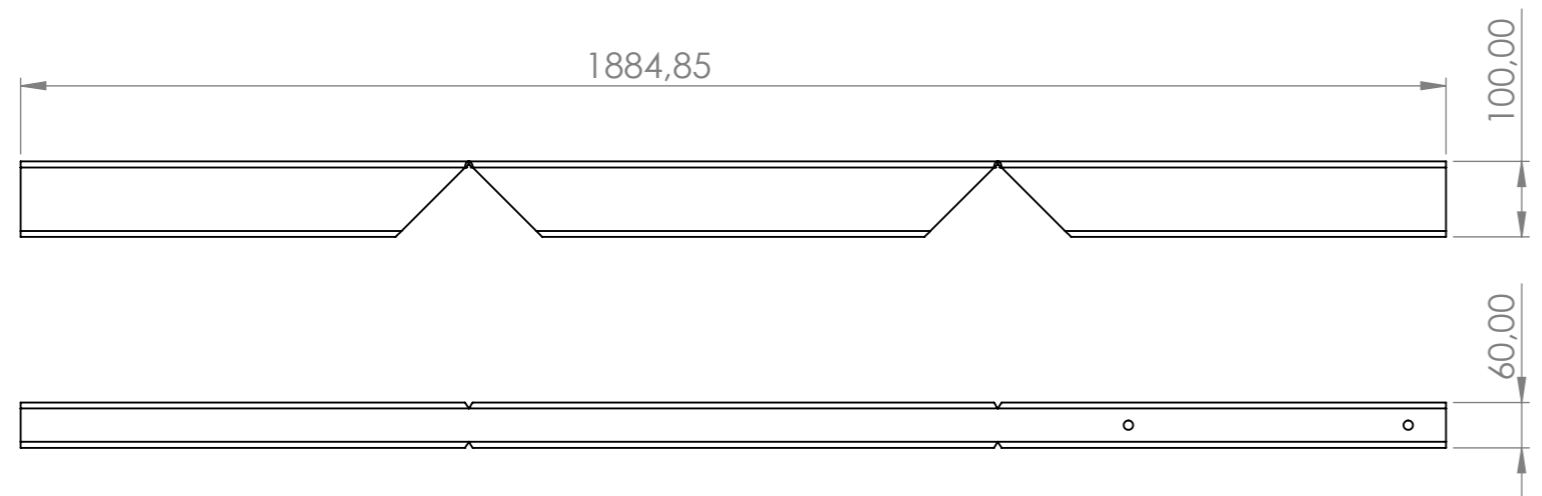
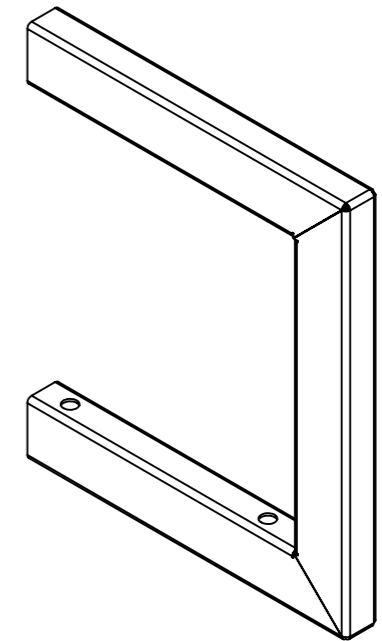
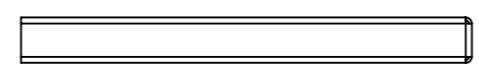
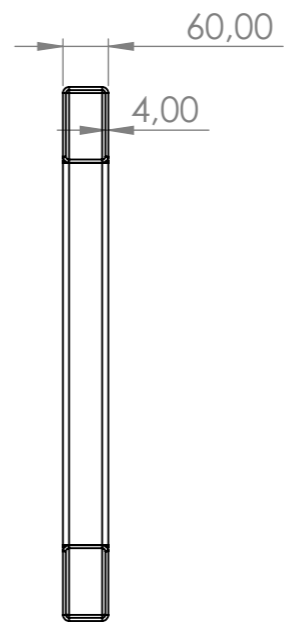
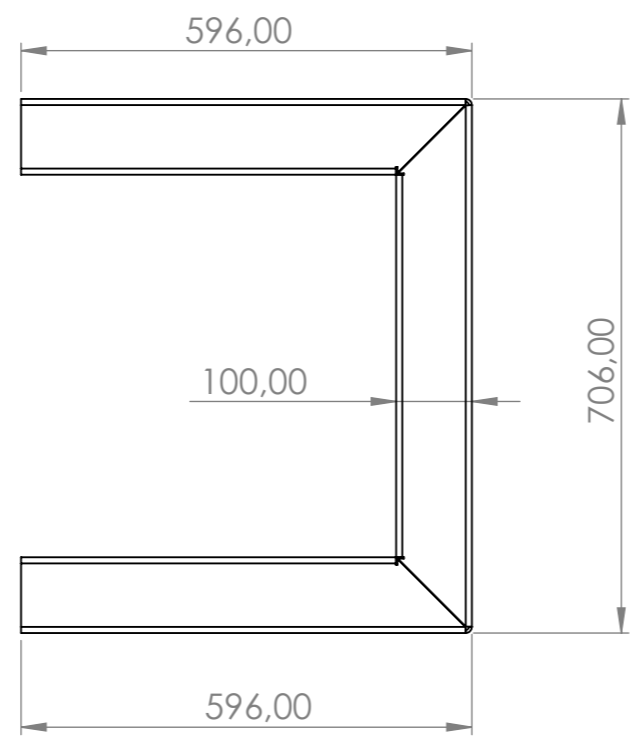

Tegnet av: LHM	Dato: 2022-10-14	<b>Tegningsnummer:</b> 105844	<b>Revisjon:</b> 01	Side: <b>3 AV 6</b>	Denne Tegningen er vår eiendom, kopiering, bruk eller videreformidling av denne tegninger uten vår tillatelse er ikke tillat. © VMV Production AS
Konstruert av: LHM	Dato: 2021-10-04	Kundens tegn. nr.: Halv Vera		Rev.:	
Titel: Halv Vera		Målestokk A3: 1:10		Generelle toleranser NS-ISO 2768-1: C	



1 2 3 4 5 6 7 8

1 2 3 4 5 6 7 8

ITEM NO.	QTY.	Tegningsnummer	Beskrivelse	Material	Vekt	Dim
1	1	105844-02	Vinkel 100x65x7	S355	3.12	7 mm

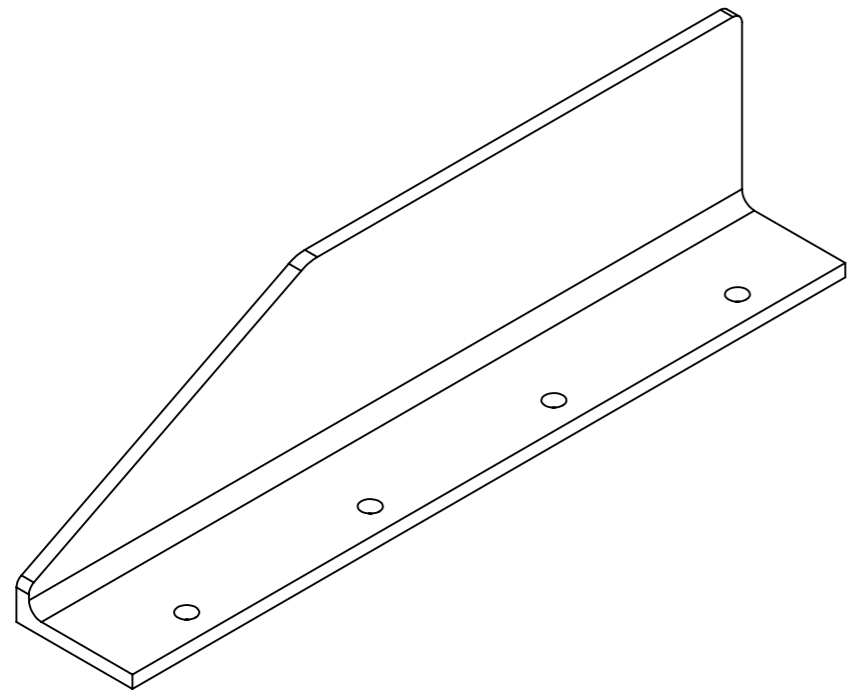
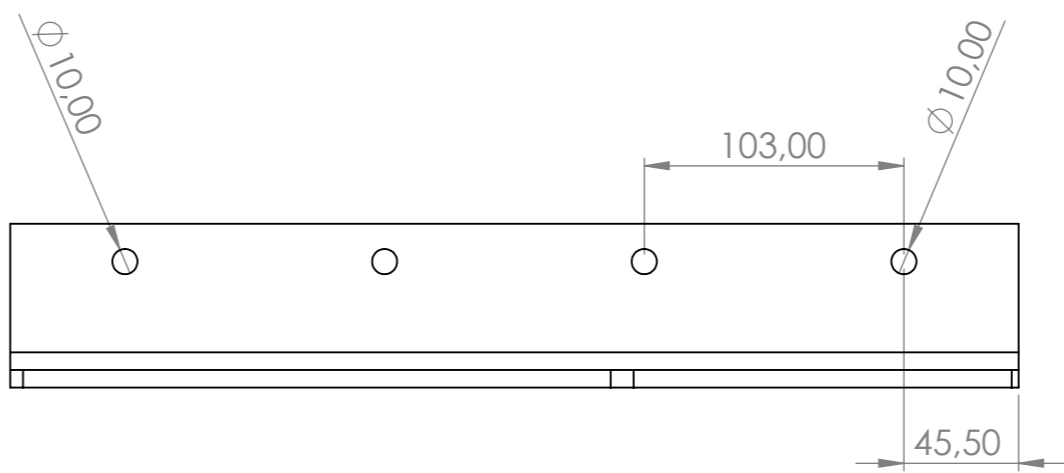
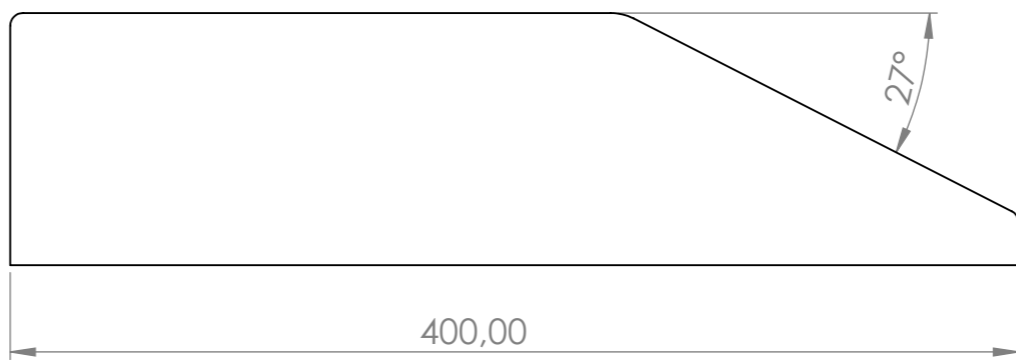
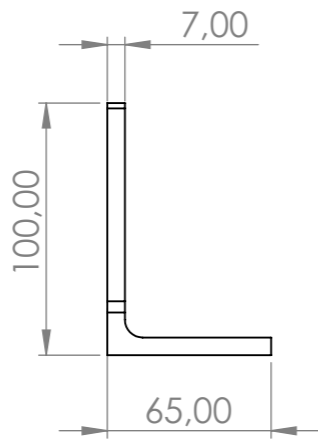

Tegnet av: LHM	Dato: 2022-10-14	<b>Tegningsnummer:</b> 105844	<b>Revisjon:</b> 01	Side: 4 AV 6	Denne Tegningen er vår eiendom, kopiering, bruk eller videreformidling av denne tegninger uten vår tillatelse er ikke tillat. © VMV Production AS
Konstruert av: LHM	Dato: 2021-10-04	Kundens tegn. nr.: Halv Vera		Rev.:	
Titel: Halv Vera		Målestokk A3: 1:5		Generelle toleranser NS-ISO 2768-1: C	



1 2 3 4 5 6 7 8

F  
E  
D  
C  
B  
A

F  
E  
D  
C  
B  
A

1 2 3 4 5 6 7 8

ITEM NO.	QTY.	Tegningsnummer	Beskrivelse	Material	Vekt	Dim
1	1	105844-03	Vinkel 100x65x7	S355	1.62	7 mm

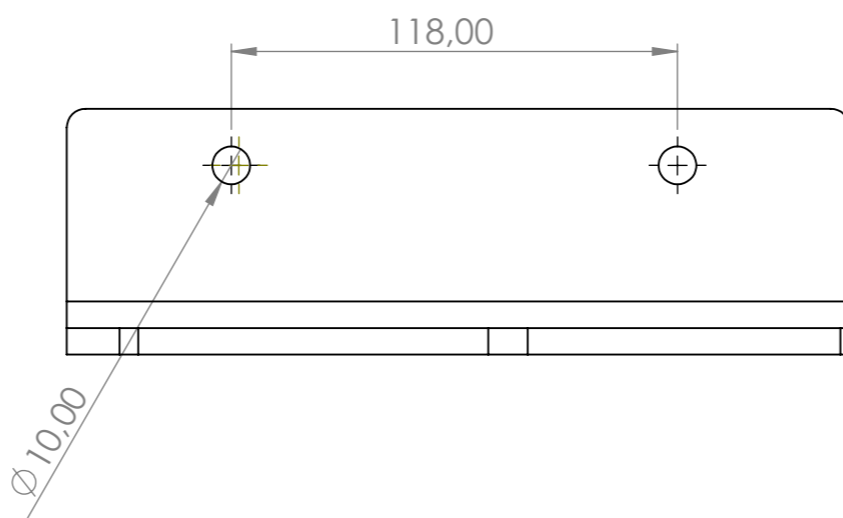
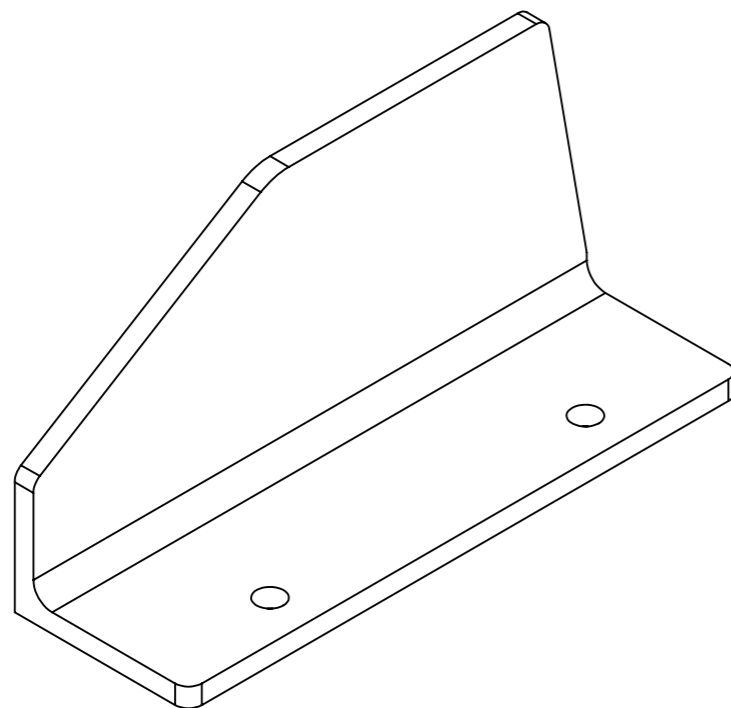
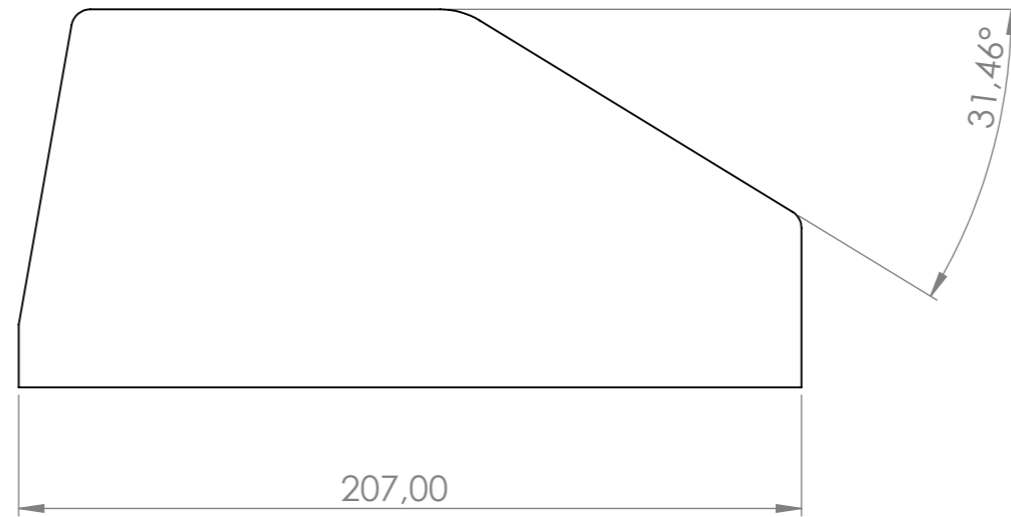
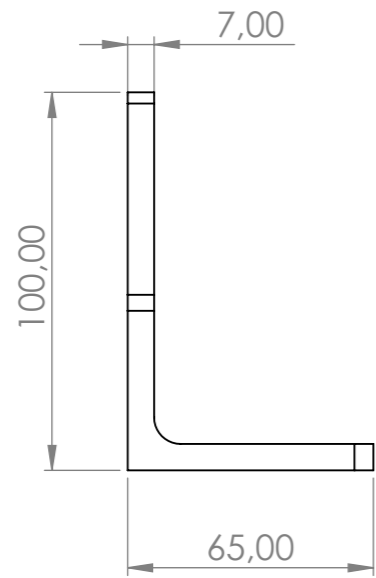

Tegnet av: LHM	Dato: 2022-10-14	<b>Tegningsnummer:</b> 105844	<b>Revisjon:</b> 01	Side: 5 AV 6	Denne Tegningen er vår eiendom, kopiering, bruk eller videreformidling av denne tegninger uten vår tillatelse er ikke tillat. © VMV Production AS
Konstruert av: LHM	Dato: 2021-10-04	Kundens tegn. nr.: Halv Vera		Rev.:	
Titel: Halv Vera				Målestokk A3: 1:5	Generelle toleranser NS-ISO 2768-1: C

**VMV**  
Production AS

1 2 3 4 5 6 7 8

F  
E  
D  
C  
B  
A

F  
E  
D  
C  
B  
A

1 2 3 4 5 6 7 8

ITEM NO.	QTY.	Tegningsnummer	Beskrivelse	Material	Vekt	Dim
1	1	105844-04		S355	0.11	3 mm

F

F

E

E

D

D

C

C

B

B

A

A

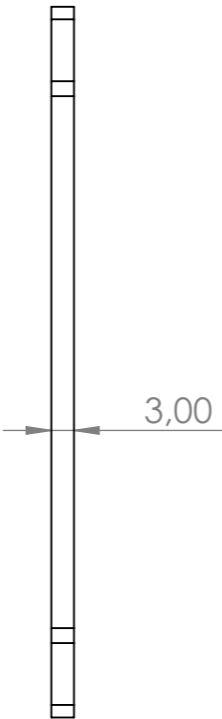
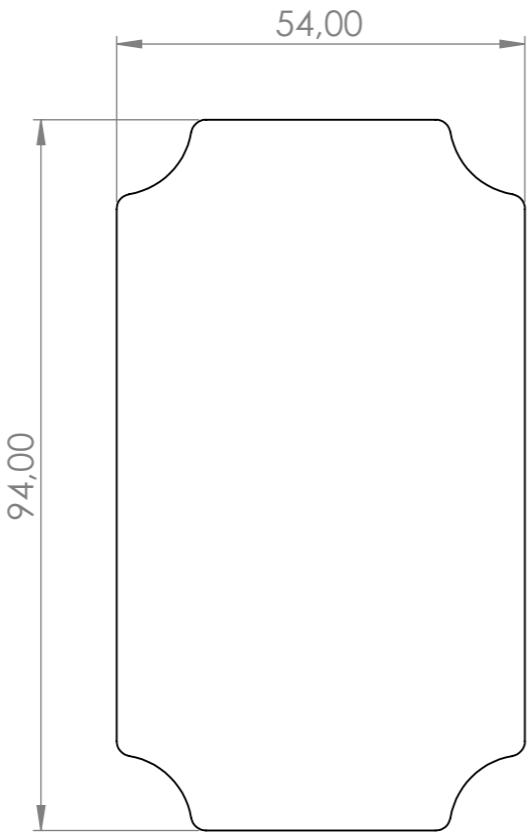

Tegnet av: LHM	Dato: 2022-10-14	<b>Tegningsnummer:</b> 105844	<b>Revisjon:</b> 01	Side: 6 AV 6	Denne Tegningen er vår eiendom, kopiering, bruk eller videreformidling av denne tegninger uten vår tillatelse er ikke tillat. © VMV Production AS
Konstruert av: LHM	Dato: 2021-10-04	Kundens tegn. nr.: Halv Vera		Rev.:	
Titel: Halv Vera		Målestokk A3: 1:1		Generelle toleranser NS-ISO 2768-1: C	
<b>VMV</b> Production AS					

1 2 3 4 5 6 7 8